

INSTALLER'S & OWNER'S MANUAL

HVAC INSTALLER: PLEASE LEAVE MANUAL FOR HOMEOWNER

Ultra-Aire™ XT150H

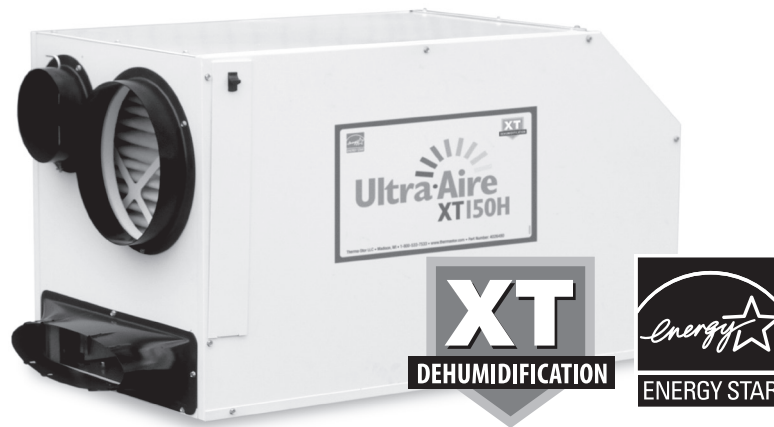

Dehumidification

The highly efficient Ultra-Aire XT150H dehumidifier utilizes refrigeration to cool the incoming air stream below its dew point. This cooled and drier air is used to pre-cool the incoming air stream resulting in a significant increase in overall efficiency. After the pre-cooling stage, the processed air is reheated by passing through the condenser coil. The heat removed by the evaporator coil is returned to the air stream, resulting in an overall temperature increase of the air leaving the unit.

The Ultra-Aire XT150H is controlled by 24 volt remote wired controls. A variety of controls are available suitable to various applications.

Fresh Air Ventilation

Optional fresh outdoor air may be ducted to the unit via a six inch round duct. This provides fresh air to dilute pollutants and maintain high oxygen content in the air. The amount of fresh air ventilation can be regulated by a variety of dampers and controls.

Air Filtration

The Ultra-Aire XT150H includes air filtration to improve indoor air quality. A MERV-11 media filter is standard. An optional external MERV-14 deep pleated 95% media filter is available for optimum air filtration and to reduce potentially harmful airborne particles. If the optional filter is chosen, a standard filter operates as a prefilter.

P/N 4026480 • Serial No. _____ Install Date: _____

Sold by:

TABLE OF CONTENTS

Table of Contents

Safety Precautions.....	3	7.5 Impeller Fan Replacement	13
1. Intended Application	4	7.6 Compressor/Capacitor Replacement.....	14
2. Specifications	4	7.6A Checking Compressor Motor Circuits	14
3. Installation	4	7.6B Replacing Burned Out Compressor	14
3.1 Location	4	7.6C Replacing Compressor-Nonburn Out.....	15
3.2 Electrical Requirements.....	4	7.7 Remote Controls.....	15
3.3 Condensate Removal.....	5	7.7A Humidity Control.....	15
3.4 Ducting.....	5	7.7B Ventilation Timer.....	15
3.4A Installing Duct Collars	5	7.8 Defrost Thermostat.....	15
3.4B Ducting for Dehumidification	5	7.9 Electric Ventilation Damper.....	15
3.4C Ducting for Fresh Air.....	6	7.10 Condensate Pump Kit	15
3.4D Installation in a Basement	6	Electrical Schematic	16
3.4E Installation in a attic	7	Pictorial Electrical Diagram.....	17
3.4F Installation with (2) HVAC systems.....	7	Service Parts List	18
3.4G Installation without an HVAC system.....	7	Optional Parts List	19
3.5 Quiet Installation.....	7	Door and Collar Assembly	20
4. Controls	7	Warranty.....	21
4.1A Humidity/Fan Control Panel WITHOUT Fresh Air Ventilation or Damper.....	8		
4.1B Humidity/Fan Control Panel WITH Fresh Air Ventilation and WITHOUT Damper.....	8		
4.1C Humidity/Fan Control Panel WITH Fresh Air Ventilation AND Damper	8		
4.1D Ventilation Timer and Humidity Control WITH Fresh Air AND Motorized Damper.....	8		
4.1E DEH 3000 Digital Control WITH Fresh Air AND Damper.....	8		
4.1F DEH 3000 Digital Control WITHOUT Fresh Air	9		
4.2 Humidity Control Adjustment	8		
4.3 Fan/Filter Switch.....	8		
4.4 Ventilation Timer.....	8		
4.4A Setting the Time	9		
4.4B Ventilation Schedule	9		
4.4C Automatic or Manual Mode.....	9		
Controls Wiring Diagram	10		
5. DEH 3000/DEH 3000R Digital Control	11		
6. Maintenance.....	12		
6.1 Standard Air Filter	12		
6.2 High Efficiency Air Filter	12		
6.3 Impeller Fan Oiling.....	12		
6.4 Fresh Air Return	12		
7. Service	12		
7.1 Warranty	12		
7.2 Technical description	12		
7.3 Troubleshooting	12		
7.4 Refrigerant Charging	13		

SAFETY PRECAUTIONS

Safety Precautions

Read the installation, operation and maintenance instructions carefully before installing and operating this device. Proper adherence to these instructions is essential to obtain maximum benefit from your Ultra-Aire XT150H indoor air quality system.

READ AND SAVE THESE INSTRUCTIONS

- The device is designed to be installed INDOORS IN A SPACE THAT IS PROTECTED FROM RAIN AND FLOODING.
- Install the unit with space to access the back or side panels for maintenance and service. DO NOT INSTALL UNIT WITH THE SERVICE PANELS INACCESSIBLE.
- Avoid directing the discharge air at people, or over the water in pool areas.
- If used near a pool or spa; be certain there is NO chance the unit could fall into the water, be splashed and that it is plugged into a GFI GROUND FAULT INTERRUPT OUTLET.
- DO NOT use the device as a bench or table.
- DO NOT place the device directly on structural members. Provide vibration isolation in order to minimize operational vibration and/or noise.
- A drain pan MUST be placed under the unit if installed above a living area or above an area where water leakage could cause damage

FOR HVAC INSTALLER ONLY

1. Intended Application for Ultra-Aire XT150H

For the ideal installation, draw air from the central part of the home and return it to isolated areas of the home like the bedrooms, den, utility room, or family room. The ductwork of the existing heating system can be used to supply air to the home.

2. Specifications

Part Number:	4026480
Blower:	415 CFM @ 0.0" WG 365 CFM @ 0.4" WG
Power:	800 Watts @ 80°F and 60% RH
Supply Voltage:	110-120 VAC – 1 Phase – 60 Hz.
Current Draw:	6.9 Amps
Energy Factor:	3.74
Operating Temp.:	56°F Min, 100°F Max
Sized For:	3500 Square Foot Typical
Minimum Performance @ 80°F and 60% RH:	
Water Removal:	150 Pints/Day
Efficiency:	7.9 Pints/kWh
UA-XT150H Duct Connections:	
6" Round Inlet; 10" Round Inlet; 10" Oval Outlet	
Air Filter:	Standard MERV-11; Size: 16" x 20" x 2" Efficiency: 65% ASHRAE Dust Spot Test Optional MERV-14, Size: 20" x 24" x 4" Efficiency: 95% ASHRAE Dust Spot Test
Power Cord:	7', 110-120 VAC, Ground
Drain Connection:	.62" ID x 8' Vinyl Hose

UA-XT150H Dimensions:

	Unit	Shipping
Width:	37 1/2" without collars 39 1/2" with collars	42"
Height:	22"	28 1/4"
Depth:	20 5/8"	24"
Weight:	134 lbs	164 lbs

3. Installation

3.1 Location

The Ultra-Aire XT150H can be installed in a variety of locations to meet the owner's needs as listed below. In all cases keep the following cautions in mind:

- It is designed to be installed INDOORS IN A SPACE THAT IS PROTECTED FROM RAIN AND FLOODING.
- Install the unit with space to access the back and side panels for maintenance and service and also to allow easy access to the filter cover panel. DO NOT INSTALL UNIT WITH THE FRONT PANEL OR FILTER COVER PANEL INACCESSIBLE.
- Avoid discharging the air directly at people, or over the water in pool areas.

- If used near a pool or spa, be certain there is NO chance the unit could fall into the water or be splashed and that it is plugged into a GROUND FAULT INTERRUPTER.
- DO NOT use the Ultra-Aire XT150H as a bench or table.
- DO NOT place the Ultra-Aire XT150H directly on structural members. Provide vibration isolation in order to minimize operational vibration and/or noise.
- A drain pan MUST be placed under the unit if installed above a living area or above an area where water leakage could cause damage.

Place the Ultra-Aire XT150H on supports that raise the base of the unit above the top of the flanges on the drain pan beneath it. Raising the Ultra-Aire XT150H will help the unit drain with gravity flow. Do not place the Ultra-Aire XT150H directly on structural building members without vibration absorbers or unwanted noise may result.

The Ultra-Aire XT150H may be suspended with steel hanger straps (plumbers tape) or a suitable alternative from structural members, unit must be supported from underneath. Don't hang from sides or ends. Remember to place a drain pan under the unit if it is suspended above a finished area or above an area where water leakage could cause damage.

The Ultra-Aire XT150H should be located near the existing air handling system to minimize the required ductwork for connecting the Ultra-Aire XT150H to the existing air handling system. The controls for the Ultra-Aire XT150H are remote from the unit and must be located in the space that is to be conditioned. The controls are low voltage (24 volt) and should be connected to the Ultra-Aire XT150H with low voltage thermostat cable.

If fresh air ventilation is desired, thought should be given to the location for the fresh air ducting. A 6" round insulated duct will have to be installed on the Ultra-Aire XT150H and run to the outside of the structure to bring in fresh air. Use an 8" insulated round duct for lengths of more than 50 feet or if more than 100 CFM is needed. Consult local codes for necessary distances from exhaust ports when installing fresh air return.

3.2 Electrical Requirements

 **WARNING! DO NOT ALLOW THE YELLOW LEAD FROM THE ULTRA-AIRE TO CONTACT THE RED LEAD OR WHITE LEAD FROM THE ULTRA-AIRE OR DAMAGE TO THE TRANSFORMER WILL RESULT.**

The Ultra-Aire XT150H plugs into a common grounded outlet. It draws around 6.9 Amps under normal operating conditions. If used in a wet area (pool, spa room, or basement prone to flooding), a ground fault interrupter protected circuit is required.

FOR HVAC INSTALLER ONLY

Install the remote control panel in a central area of the structure where it will sense the relative humidity of the structure accurately. Do not install the control panel where it may not accurately sense the relative humidity such as near HVAC supply registers, near exterior doors, or near a pool or spa. The installer must supply the wiring between the Ultra-Aire XT150H and the control panel. Be sure to safely route the control wiring to prevent damage during installation. Be careful not to cross the wires when connecting the Ultra-Aire XT150H and the remote control panel or damage to the transformer may result.

The remote controls of the Ultra-Aire XT150H are powered by a low voltage circuit (24 Vac) and must NEVER contact or be connected to a high voltage circuit. The control wires leaving the Ultra-Aire XT150H and the remote control panels are numbered and color-coded to prevent confusion. Some of the control wires leaving the Ultra-Aire XT150H may not be used with certain control panels and should be left safely disconnected with wire nuts taped onto the stripped ends. Be sure to consult the electrical schematic in this manual or inside the access panel of the Ultra-Aire XT150H before making the control connections.

3.3 Condensate Water Removal

Condensate drains by gravity via the drain port. Use 3/4" male NPT PVC pipe. Route drain pipe to drain. Install a trap if possible. Take care when installing drain pipe to drain port. Use an adjustable wrench to secure the drain port. An optional condensate pump kit may be installed if a lift is required to dispose of the condensate. The condensate pump kit can be ordered directly from the factory. See the optional parts list for information on the kit.

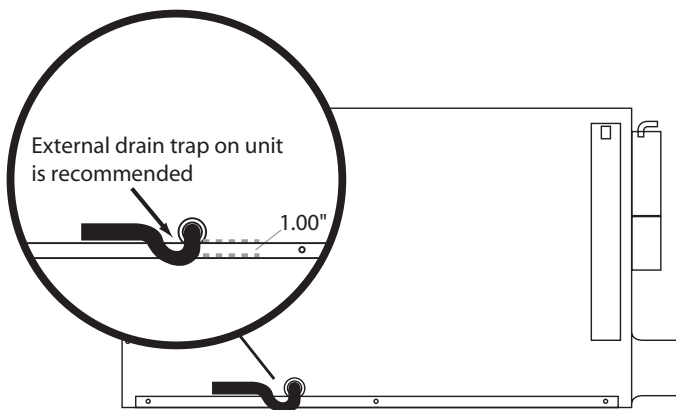

3.4 Ducting

3.4A Installing Duct Collars

The Ultra-Aire XT150H is equipped with 10" and 6" round inlet collars and a 10" round (ovaled) exhaust collar. Follow instructions included with collars.

3.4B Ducting for Dehumidification

For the ideal installation, draw air from the central part of the home and return it to the isolated areas of the home like the bedrooms, den, utility room, or family room. The ductwork of the existing heating system can be used to supply air to the home. If the existing supply goes to isolated areas of the home, discharge the supply of the Ultra-Aire XT150H into the supply of the existing heating system. If the existing heating system incorporates a central supply, installation of a separate supply duct from the Ultra-Aire XT150H to each isolated area is recommended. DO NOT draw air directly from the kitchen, laundry, or isolated basement. You may draw air from a basement that is open to the home. All flexible ducting connected to the Ultra-Aire XT150H should be UL listed.

The inlet of the Ultra-Aire XT150H is the 10" diameter hole in the filter enclosure of the unit. A 10" round collar is supplied with the unit to attach to round duct. The duct may be permanently attached to the collar. A 6" round collar is provided with the unit to attach to the 6" hole in the filter enclosure. The 6" collar should be capped if fresh make-up air is not desired. If fresh make-up air is desired, see Section 3.4C.

A 10" round (ovaled) collar is supplied with the unit for the outlet of the Ultra-Aire XT150H.

A length of flexible ducting on all Ultra-Aire XT150H duct connections is recommended to reduce noise and vibration transmitted to rigid ductwork in the structure.

Ducting the Ultra-Aire XT150H as mentioned in Sections 3.4A-3.4G requires consideration of the following points:

Duct Sizing: For total duct lengths up to 25', use a minimum 10" diameter round or equivalent rectangular. For longer lengths, use a minimum 12" diameter or equivalent. Grills or diffusers on the duct ends must not excessively restrict airflow.

Isolated Areas: Effective dehumidification may require that ducting be branched to isolated, stagnant areas. Use 8" or larger diameter branch ducting to each of two or three areas, use 6" or larger to each of four or more areas.

Connecting to existing HVAC systems: An optional 10" check damper is available from the factory to prevent reverse flow through the Ultra-Aire XT150H. If the Ultra-Aire XT150H is ducted to the supply ducting air handler, it is recommended that the check damper be placed in the Ultra-Aire XT150H supply duct. Contact the factory when connecting to a static pressure of greater than or equal to +.5" WG.

3.4C Ducting for Fresh Air

Fresh air can be brought into the structure by connecting an insulated duct from outside to the 6" Ultra-Aire XT150H inlet and by turning on the fan switch or activating the humidity control (on units with the humidity control panel). Activate the ventilation timer on units with the ventilating and humidity control panel to bring in fresh air. Refer to Section 4.5 for programming instructions for the ventilation timer. Advantages of this form of ventilation include:

1. Outside air is filtered before entering the building.
2. Outside air will be dehumidified before entering if the Ultra-Aire XT150H is running in dehumidification mode.
3. Drawing air from outside and blowing inside aids in slightly pressurizing the structure. This helps prevent dirty and humid air from entering elsewhere. It also reduces the potential for carcinogenic radon gas to enter and provides make-up air for open combustion and exhaust devices like the clothes drier, fireplace, and water heater.
4. Adequate exhaust fans are recommended in the bath rooms and kitchen.

In cold climates or areas where the outdoor dew point is low at times, ventilation can be used to dehumidify the structure. This is accomplished by bringing the dry, low dew point air into the structure during these times. This approach is often more economical than running the dehumidifier to remove excess moisture from the structure. In cold climates, it is critical to adequately ventilate to reduce the inside moisture content to avoid moisture accumulating in the wall cavities. For example; in a house that experiences condensation on the interior surface of the windows during the winter, increasing the amount of ventilation will often cure the problem.

An insulated 6" diameter duct is generally sufficient to provide up to 125 CFM of outside air. Large quantities of outside air will either positively or negatively impact the performance of the Ultra-Aire XT150H, depending upon inside and outside air conditions. Consult the factory by calling 1-800-533-7533 for recommendations regarding the use of higher flows with your specific application.

The outside air duct should be connected to the 6" round collar on the filter enclosure of the unit. The 6" round collar includes a manual damper. Adjust the manual damper to provide the desired amount of fresh air for ventilation. The amount of fresh air should be based on the size and occupancy of the residence. If you are unsure of your ventilation air requirements, consult the factory by calling 1-800-533-7533 for assistance.

3.4D Installation in a Basement or Crawlspace with an Existing Forced Air HVAC System

It is recommended that a new, separate return duct be installed for the Ultra-Aire XT150H from a central area of the house. If this is not possible, and if the existing system has multiple returns, select one to disconnect from the existing forced air system and use it for the

dedicated Ultra-Aire XT150H return. Always select a return from a central location in the structure in an area that is always open to the rest of the structure. Do not use a return from a room that may have its door closed much of the time.

If the structure in which the Ultra-Aire XT150H is to be installed has an existing forced air HVAC system, utilize the HVAC system to make the Ultra-Aire XT150H installation easier.

Basement Installation: Install a separate 10" return for the Ultra-Aire XT150H in a central area of the structure. Duct the supply of the

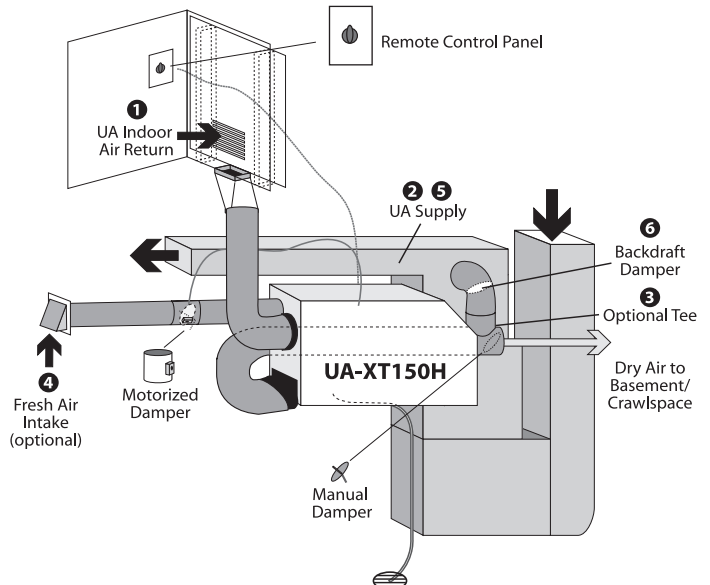

Ultra-Aire XT150H to an optional 10" x 10" x 10" tee/damper that is 20% open to the basement. This allows the ability to discharge a variable amount of dehumidified air into a basement that may not be well served by the existing duct system. Duct the other side of the tee to the air supply of the existing HVAC system. A backdraft damper is required in the duct between the 10" tee and the central supply duct to prevent air from being discharged into the basement during central fan operation. Connect a duct from outside to the 6" collar of the Ultra-Aire XT150H if you wish to provide fresh air ventilation.

Crawl Space Installation: Install a separate return for the Ultra-Aire XT150H in a central area of the structure. Duct the supply of the Ultra-Aire XT150H to a 10" x 10" x 10" tee/damper that is 20% open to the crawl space if desired. Duct the other side of the tee to the air supply of the existing HVAC system ventilation. Connect an insulated duct from outside to the 6" collar of the Ultra-Aire XT150H if you wish to provide optional fresh air.

3.4E Installation in an Attic with an Existing Forced Air HVAC System

ALWAYS install a catch pan with a drain and/or float interrupt switch for condensate under the Ultra-Aire XT150H in an attic to reduce likelihood of water damage.

Locate a separate return for the Ultra-Aire XT150H in a central

FOR HVAC INSTALLER ONLY

area of the structure. Duct the supply of the Ultra-Aire XT150H to the air supply of the existing HVAC system. Connect an insulated duct from outside to the 6" collar of the Ultra-Aire XT150H if you wish to provide fresh air ventilation. Adjust damper in the collar to provide the desired amount of fresh air. Using a remote control, program the unit to bring in the desired amount of fresh air.

3.4F Installation in a Structure with Two Forced Air HVAC Systems

The Ultra-Aire XT150H can be installed into two typical HVAC ducting systems. Install a separate return for the Ultra-Aire XT150H as directed above. Discharge air from the dehumidifier should be split and routed to each supply ducting system. A balancing damper

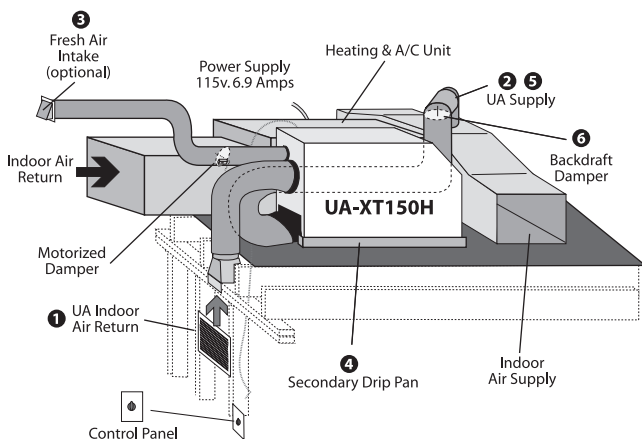

and a backdraft damper is required in each duct between the Ultra-Aire XT150H and the HVAC ducting system. This allows airflow to be adjusted and prevents flow of air between the ducting systems. Contact the factory for assistance, if necessary.

3.4G Installation in a Structure with No Existing Forced Air HVAC System

When installing the Ultra-Aire XT150H in a structure that does not have a forced air HVAC system, a single return for the Ultra-Aire XT150H should be installed in central open area of the structure. DO NOT locate the return in a bathroom or a kitchen. The supply of the Ultra-Aire XT150H should be located in the remote areas of the structure (such as bedrooms, den, etc.). By ducting this way, the air inside the structure will circulate through the Ultra-Aire XT150H to be filtered and dehumidified. Avoid discharging all the air from the dehumidifier in one location to prevent heat build up in that area. 4" diameter duct is recommended for branches to the bedrooms, 6" diameter duct is recommended for branches to larger areas. Refer to section 3.4B for branch duct sizing. Connect an insulated duct from outside to the 6" collar of the Ultra-Aire XT150H if you wish to provide fresh air ventilation.

3.5 Quiet Installation

Consider compression vibration and airflow noise during installation. Use of flex duct and/or vibration isolation materials

during mounting and ducting will result in quieter operation.

A length of flexible ducting on all Ultra-Aire XT150H duct connections is recommended to reduce noise and vibration transmitted to rigid ductwork in the structure.

4. Controls

The Ultra-Aire can be equipped with various accessories to enhance its operation. A remote control must be used with the Ultra-Aire. ThermaStor offers the DEH 3000 proprietary controller. The DEH 3000 allows homeowners the ability to monitor and control relative humidity levels in their home. This control is also offered with a remote sensing option.

WARNING: DO NOT allow the yellow lead from the unit to contact the red lead or the white lead from the unit or damage to the transformers will result.

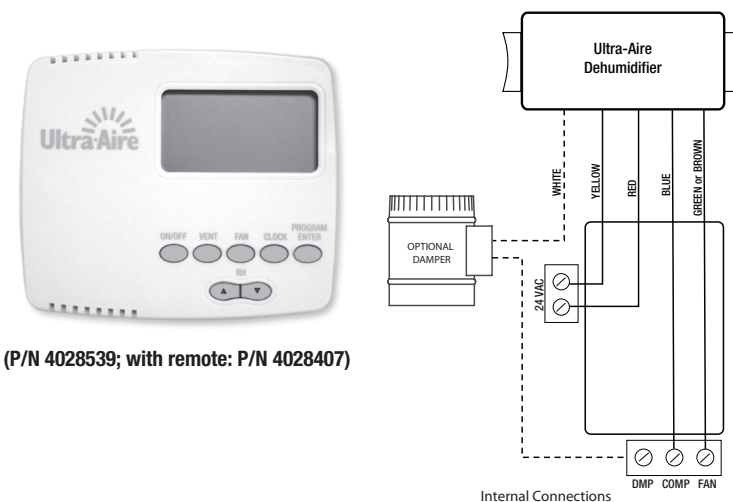

(P/N 4028539; with remote: P/N 4028407)

The UA dehumidifier is controlled using five color-coded wires.

Green (or brown) = Fan control

Blue = Dehumidification (fan and compressor) control

Red = 24volt AC power transformer neutral side (common with white)

White = 24volt AC power transformer neutral side (common with red)

Yellow = transformer high side

Between the red/white lead and the yellow leads is a 40VA transformer. This low voltage power source powers the relay coils which control the fan and compressors. This 24VAC transformer can also be used to power HVAC accessories external to the dehumidifier.

- To turn the dehumidifier on make contact between yellow and blue wires.
- To turn the fan on make contact between yellow and green(or brown) wires.
- To power an HVAC accessory, connect the accessory to the white (or red) wire and the yellow wire.

ATTENTION INSTALLER

WARNING: Allowing yellow wire to contact red or white wire will destroy the transformer.

Dehumidifier on : Connect yellow and blue wires.

Fan only on : Connect yellow and green (or brown) wires.

Accessory power : 24volt AC power supply available for HVAC accessories between yellow and white(and/or red) wire. Red and white wires are common with each other.

Ultra-Aire DEH 3000 dehumidification & ventilation control

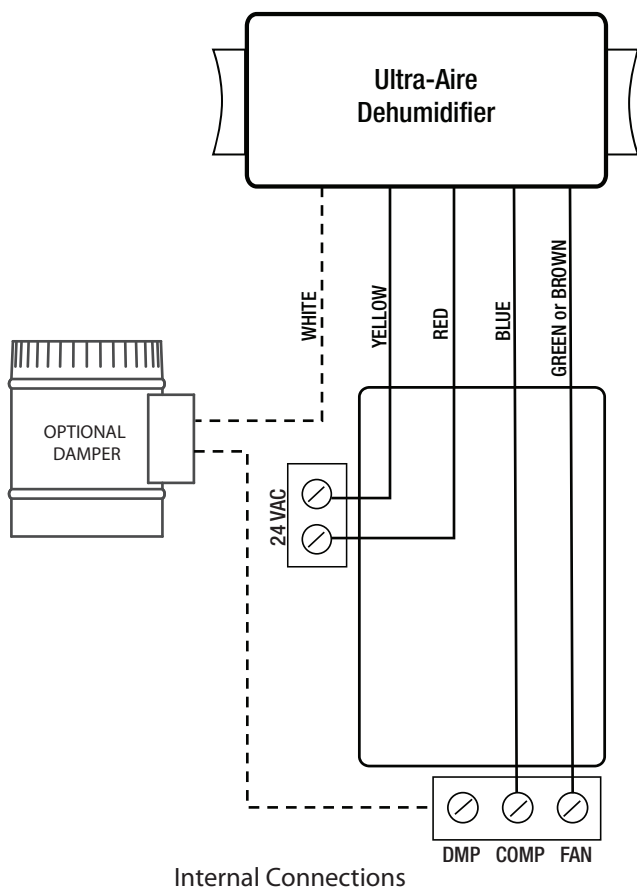

(P/N 4028539; with remote: P/N 4028407)

Ultra-Aire™
DEH 3000/DEH 3000R
Part No. 4028539 Part No. 4028407



5. Optional Dehumidifier & Ventilation System Controller

When used with Ultra-Aire Whole House Ventilating Dehumidifiers, the DEH 3000/3000R allows homeowners the ability to monitor and control relative humidity levels in their home.

DEH3000 P/N:	4028539
DEH3000R (remote) P/N:	4028407
Model:	DEH 3000 DEH 3000R (remote)
Operating Voltage:	24 VAC
Max Current DMP, COMP, FAN:	1 AMP each
Humidity Range/Accuracy:	10 – 95% RH, ± 5%
Auxillary Relay Capacity:	5 Amps, 24VAC
Temp Range/Accuracy:	30°-90°F, 2%
Size:	4.95"L x 1.06"W x 4.19"H

Major Operations

- Digital control of Relative Humidity (Digital Set-Point)
- Fan/Filter Operation
- Programmable Ventilation Timer
- Large, easy-to-read backlit LCD display
- Easy interaction with air handler fan (Interlock/Lockout)
- High Temperature Cut-Out
- Dryout Cycle Timer
- Auto Reboot
- Remote Sensor (DEH 3000R Only)

**To order call Therma-Stor at
1-800-533-7533**

6. Maintenance

6.1 Standard Air Filter

The Ultra-Aire XT150H is equipped with a pleated cloth air filter. This filter should be checked every six months. Operating the unit with a dirty filter will reduce dehumidifier capacity and efficiency and may cause the compressor to cycle off and on unnecessarily on the defrost control.

To access the air filter, remove the filter access panel from the end of the Ultra-Aire XT150H. The filter should be readily visible and can be removed by pulling them straight out of the Ultra-Aire XT150H.

The pleated cloth filter can generally be vacuumed clean several times before needing replacement. Replacement filters can be ordered from the factory or purchased locally if available. **DO NOT** operate the unit without the standard filter or with a less effective filter than the standard filter. The heat exchange coils inside the unit could become clogged and require disassembly to clean. Filter non-compliance invalidates the product warranty.

6.2 High Efficiency Air Filter

An optional high efficiency pleated microglass paper filter is available for the Ultra-Aire. This filter is rated as 90%-95% efficient by the ASHRAE Dust Spot test method 52-76. The high efficiency pleated microglass paper filter should be used in conjunction with the standard filter, and placed directly beneath the standard filter.

This filter is able to remove allergy causing particles from the airstream. The high efficiency filter has a much larger surface area than the standard filter, thus the standard filter may need to be cleaned or replaced several times before the high efficiency filter requires replacement. Be careful not to damage the fabric media when handling the high efficiency pleated paper filter. Do not attempt to clean the high efficiency pleated paper filter. It should be replaced when it becomes restrictive (See Figure 7).

6.3 Impeller Fan Oiling

The impeller fan motor is factory lubricated for many years of normal operation, and no further oiling is required.

6.4 Optional Fresh Air Return

Check and clean the screen on the outdoor fresh air return seasonally. The screen may become plugged during the seasons when there are many particles in the outdoor air.

7. Service

7.1 Warranty

A warranty certificate has been enclosed with this unit; read it before any repair is initiated. If a warranty repair is required, call the factory first at 1-800-533-7533 for warranty claim authorization and technical assistance.

7.2 Technical Description

The Ultra-Aire XT150H uses a refrigeration system similar to an air conditioner's to remove heat and moisture from incoming air, and add heat to the air that is discharged (See Figure 15).

Hot, high-pressure refrigerant gas is routed from the compressor to the condenser coil (See Figure 3). The refrigerant is cooled and condensed by giving up its heat to the air that is about to be discharged from the unit. The refrigerant liquid then passes through a filter/drier and capillary tubing which causes the refrigerant pressure and temperature to drop. It next enters the evaporator coil where it absorbs heat from the incoming air and evaporates. The evaporator operates in a flooded condition, which means that all the evaporator tubes contain liquid refrigerant during normal operation. A flooded evaporator should maintain nearly constant pressure and temperature across the entire coil, from inlet to outlet.

The mixture of gas and liquid refrigerant enter the accumulator after leaving the evaporator coil. The accumulator prevents any liquid refrigerant from reaching the compressor. The compressor evacuates the cool refrigerant gas from the accumulator and compresses it to a high pressure and temperature to repeat the process.

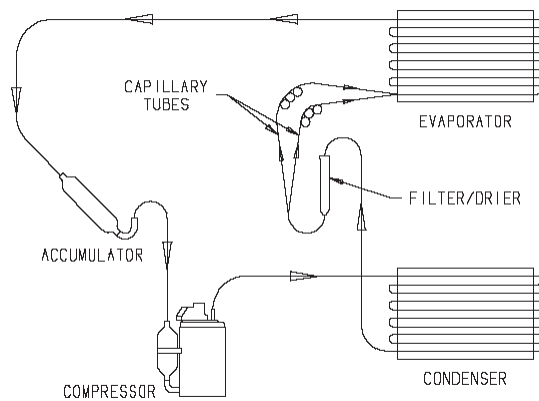

Figure 15: Refrigeration System of Ultra-Aire XT150H

7.3 Troubleshooting

Neither fan nor compressor running. Dehumidification is being called for. No fan call.

1. Unit unplugged or no power to outlet.
2. Humidity control set too high.
3. Loose connection in internal or control wiring.
4. Defective Compressor relay.
5. Defective control transformer.

Compressor is not running. Dehumidification is being called

for. No fan call.

1. Defective compressor run capacitor (Sec. 7.6).
2. Loose connection in compressor circuit.
3. Defective compressor overload (Sec. 7.6A).
4. Defective compressor (Sec. 7.6).
5. Defrost thermostat open.

Compressor cycles on and off. Dehumidification is being called for. No fan call

1. Low ambient temperature and/or humidity causing unit to cycle through defrost mode.
2. Defective compressor overload (Sec. 7.6A).
3. Defective compressor (Sec. 7.6).
4. Defrost thermostat defective (Sec. 7.8).
5. Dirty air filter(s) or air flow restricted.

Fan is not running. Dehumidification or fan is being called for

1. Loose connection in fan circuit.
2. Obstruction prevents fan impeller rotation.
3. Defective fan.
4. Defective fan relay.

Low dehumidification capacity (evaporator is frosted continuously). Dehumidification is being called for

1. Defrost thermostat loose or defective (Sec. 7.8).
2. Low refrigerant charge
3. Dirty air filter(s) or air flow restricted.
4. Excessively restrictive ducting connected to unit.

No ventilation. Ventilation is being called for.

1. Loose connection in ventilation control circuit
2. Loose connection in damper power circuit.
3. Defective fresh air damper.

Unit removes some water, but not as much as expected.

1. Air temperature and/or humidity have dropped.
2. Humidity meter and or thermometer used are out of calibration.
3. Unit has entered defrost cycle (Sec. 5.8).
4. Air filter dirty (Sec. 4.1 & 4.2).
5. Defective defrost thermostat (Sec 5.8).
6. Low refrigerant charge (Sec. 5.4).
7. Air leak such as loose cover or ducting leaks.
8. Defective compressor (Sec. 5.6).
9. Restrictive ducting (Sec. 2.4).
10. Optional Condensate Pump Safety Switch open (Sec 5.11).

Unit Test to determine problem:

1. Detach field control wiring connections from main unit.
2. Connect the yellow and green pigtails from the main unit together; only the impeller fan should run. Disconnect the wires.

3. Connect the yellow and blue pigtails from the main unit together; the compressor and impeller fan should run.
4. If these tests work, the main unit is working properly. You should check the control panel and field control wiring for problems next.
5. Remove the control panel from the mounting box and detach it from the field installed control wiring. Connect the blue, yellow, and green wires from the control panel directly to the corresponding colored pigtails on the main unit. Leave the violet, white and red wires disconnected!
6. Turn on the fan switch; the impeller fan should run. Turn off the fan switch.
7. Turn on the humidity control; the compressor and impeller fan should run.
8. If these tests work, the problem is most likely in the field control wiring.

7.4 Refrigerant Charging

If the refrigerant charge is lost due to service or a leak, a new charge must be accurately weighed in. If any of the old charge is left in the system, it must be recovered before weighing in the new charge. Refer to the unit nameplate for the correct charge weight and refrigerant type.

7.5 Impeller Fan Replacement

The motorized impeller fan is a unitary assembly consisting of the motor and impeller fan. If defective, the complete assembly must be replaced.

1. Unplug the power cord.
2. Remove the cabinet access panel.
3. Remove the screw attaching the impeller fan support bracket to the base.
4. Disconnect the impeller fan leads inside the electric box.

5. Remove fan/bracket assembly by removing 3 screws from the bracket and inlet ring assembly.
6. Remove the defective impeller fan from the bracket and replace with it with the new impeller fan.
7. Reassemble the new impeller fan by reversing the above procedure. Note: There are two pins on the backside of the cabinet that must align with the two holes in the impeller fan support bracket.

7.6 Compressor/Capacitor Replacement

This compressor is equipped with a two terminal external overload and a run capacitor, but no start capacitor or relay (See Figure 4).

7.6A Checking Compressor Motor Circuits

Perform the following tests if the impeller fan runs but the compressor does not with the fan switch and ventilation timer OFF and the humidity control ON.

1. Unplug the unit; remove the cabinet side and the electrical connection cover on the compressor top.
2. Plug in the unit and turn the humidity control to ON. Check for 110 volts from compressor terminal R to overload terminal 3 using an AC voltmeter. If voltage is present, go to step 3. If no voltage, there may be a loose connection in the compressor circuit. Test each component for continuity. See the appropriate section if a defect is suspected.
3. Unplug the unit, and then disconnect the red and yellow wires from compressor terminals R & S. Using an ohmmeter check continuity between the points listed below.
4. Compressor terminals C and S: No continuity indicates an open start winding. The compressor must be replaced. Normal start winding resistance is 3 to 7 ohms.
5. Compressor terminals C and R: No continuity indicates an open run winding. The compressor must be replaced. Normal run winding resistance is .5 to 2 ohms.
6. Compressor terminal C and overload terminal 1: No continuity indicates a defective overload lead.
7. Overload terminals 1 and 3: If there is no continuity, the overload may be tripped. Wait 10 minutes and try again. If there is still no continuity, it is defective and must be replaced.
8. Compressor terminal C and compressor case: Continuity indicates a grounded motor. The compressor must be replaced.
9. Disconnect the wires from the run capacitor. Set the ohmmeter to the Rx1 scale. The capacitor is shorted and must be replaced if continuity exists across its terminals. If there is no needle movement with the meter set on the Rx100000 scale, the capacitor is open and must be replaced.
10. Reconnect the wires to the compressor and capacitor. Plug in and turn on the unit. If the compressor fails to start,

replace the run capacitor.

11. If the unit still does not start, adding a hard-start kit (relay & capacitor) will provide greater starting torque. If this doesn't work, the compressor has an internal mechanical defect and must be replaced.

7.6B Replacing a Burned Out Compressor

The refrigerant and oil mixture in a compressor is chemically very stable under normal operating conditions. However, when an electrical short occurs in the compressor motor, the resulting high temperature arc causes a portion of the refrigerant oil mixture to break down into carbonaceous sludge, a very corrosive acid, and water. These contaminants must be carefully removed otherwise even small residues will attack replacement compressor motors and cause failures.

The following procedure is effective only if the system is monitored after replacing the compressor to insure that the clean up was complete.

1. This procedure assumes that the previously listed compressor motor circuit tests revealed a shorted or open winding.
2. Remove and properly dispose of the system charge. DO NOT vent the refrigerant or allow it to contact your eyes or skin.
3. Remove the burned out compressor. Use rubber gloves if there is any possibility of contacting the oil or sludge.
4. To facilitate subsequent steps, determine the type of burn out that occurred. If the discharge line shows no evidence of sludge and the suction line is also clean or perhaps has some light carbon deposits, the burn out occurred while the compressor was not rotating. Contaminants are therefore largely confined to the compressor housing. A single installation of liquid and suction line filter/driers will probably clean up the system.

If sludge is evident in the discharge line, it will likely be found in the suction line. This indicates the compressor burned out while running. Sludge and acid have been pumped throughout the system. Several changes of the liquid and suction filter/driers will probably be necessary to cleanse the system.

5. Correct the system fault that caused the burn out. Consult the factory for advice.
6. Install the replacement compressor with a new capacitor and an oversized liquid line filter.

In a running burn out, install an oversized suction line filter/drier between the accumulator and compressor. Thoroughly flush the accumulator with refrigerant to remove all trapped sludge and to prevent the oil hole from becoming plugged. A standing burn out does not require a suction line filter/drier.

7. Evacuate the system with a good vacuum pump and accurate vacuum gauge. Leave the pump on the system for at least an hour.
8. Operate the system for a short period of time, monitoring the suction pressure to determine that the suction filter is not becoming plugged. Replace the suction filter/drier if pressure drop occurs. If a severe running burn out has occurred, several filter/driers may have to be replaced to remove all of the acid and moisture.

NOTE: NEVER use the compressor to evacuate the system or any part of it.

7.6C Replacing a Compressor, Nonburn Out

Remove the refrigerant from the system. Replace the compressor and liquid line filter/drier. Charge the system to 50 PSIG and check for leaks. Remove the charge and weigh in the refrigerant quantity listed on the nameplate. Operate the system to verify performance.

7.7 Remote Controls

The Ultra-Aire XT150H is controlled by devices mounted on a panel that is remote from the unit. You may or may not have the devices listed below depending on the model of the remote control panel you purchased. If the Ultra-Aire XT150H fails to operate as desired, always check the settings of the controls to insure that they are correct. Check that the controls are receiving 24Vac from the Ultra-Aire XT150H. Check the connections between the Ultra-Aire XT150H, the control panel, and the field control wiring.

7.7A Humidity Control

The humidity control is an adjustable switch that closes when the relative humidity of the air in which it is located rises to the dial set point. It opens when the RH drops 4 to 6% below the set point. If the Ultra-Aire XT150H does not run, try turning the humidity control clockwise until it reaches the stop and the knob pointer points at "Max Dry" (see back of control panel cover). If it still does not run, remove the stop screw from the panel and turn the knob farther. If it then runs, the humidity control is out of calibration or the RH is below 40%.

The Ultra-Aire XT150H is equipped with an automatic defrost mechanism. If the Ultra-Aire XT150H operates in conditions that develop frost on the evaporator, it will sense the frost build-up and automatically defrost the evaporator. The Ultra-Aire XT150H may not appear to be operating correctly during the defrost sequence, but once the defrost sequence is completed, the Ultra-Aire XT150H will resume dehumidifying.

7.7B Programmable Ventilation Timer

The ventilation timer controls the impeller fan and the motorized fresh air damper. When the ventilation timer is activated, the Ultra-Aire XT150H will circulate the indoor air, and bring in fresh air from outside. The ventilation timer should be set for the required

ventilation of the residence. The home should be ventilated with fresh air as suggested by applicable codes and standards.

If the Ultra-Aire XT150H fails to ventilate as expected, check that the time on the timer is correct. For the timer to carry out the program schedule, the slide switch in the upper left corner on the timer must be set to "AUTO". The slide switch in the upper right corner of the Ultra-Aire XT150H must be set to "RUN". Also check the programs on the timer to be sure that the timer is calling for ventilation at the correct times. If the timer fails to operate or operates erratically, reset the timer; see section 4.5 of this manual.

7.8 Defrost Thermostat

The defrost thermostat is attached to the refrigerant suction tube between the accumulator and the compressor. It will automatically shut the compressor off if the low side refrigerant temperature drops due to excessive frost formation on the evaporator coil. The impeller fan will continue to run, causing air to flow through the evaporator coil and melt the ice. When the ice has melted, the evaporator temperature will rise and the thermostat will restart the compressor.

7.9 Electric Ventilation Damper

The damper will open when the ventilation is called for, allowing fresh air into the structure through the fresh air inlet duct. The electric ventilation damper will remain closed when the ventilation is not activated in order to prevent over-ventilating the structure when the unit is dehumidifying or recirculating the indoor air. The electric ventilation damper operates on 24 Vac from the control circuit. DO NOT connect high voltage to the damper motor or damage to the motor will result. DO NOT force the blade of the damper by hand or damage to the damper motor may result.

The damper opens in one direction only. The damper rotates very slowly, allow sufficient time for the damper to cycle. The damper will take approximately 1 minute to cycle from closed to open or from open to closed.

If the electric ventilation damper fails to operate:

1. Check that the wiring is correct and that voltage is present at the damper motor.
2. Check for any obstruction inside the damper. If the electric ventilation damper fails to operate after performing these checks, it must be replaced.

7.10 Condensate Pump Kit

An optional condensate pump kit is available from the factory for use with the Ultra-Aire XT150H. Condensate is automatically pumped to a remote location when the water level in the pump's reservoir rises to close the float switch.

FOR HVAC INSTALLER ONLY

The pump also contains a safety float switch. The white leads from this switch extend from beneath the pump cover. This switch should be installed in series with the field wire that connects the blue (#5) lead from the Ultra-Aire XT150H to the blue (#5) lead on the control panel.

If the pump fails, this switch opens the compressor control circuit and stops water production before the reservoir overflows. The Ultra-Aire XT150H will continue to ventilate or circulate air as normal, but will not dehumidify until this switch closes.

Electric Schematics of the Ultra-Aire XT150H

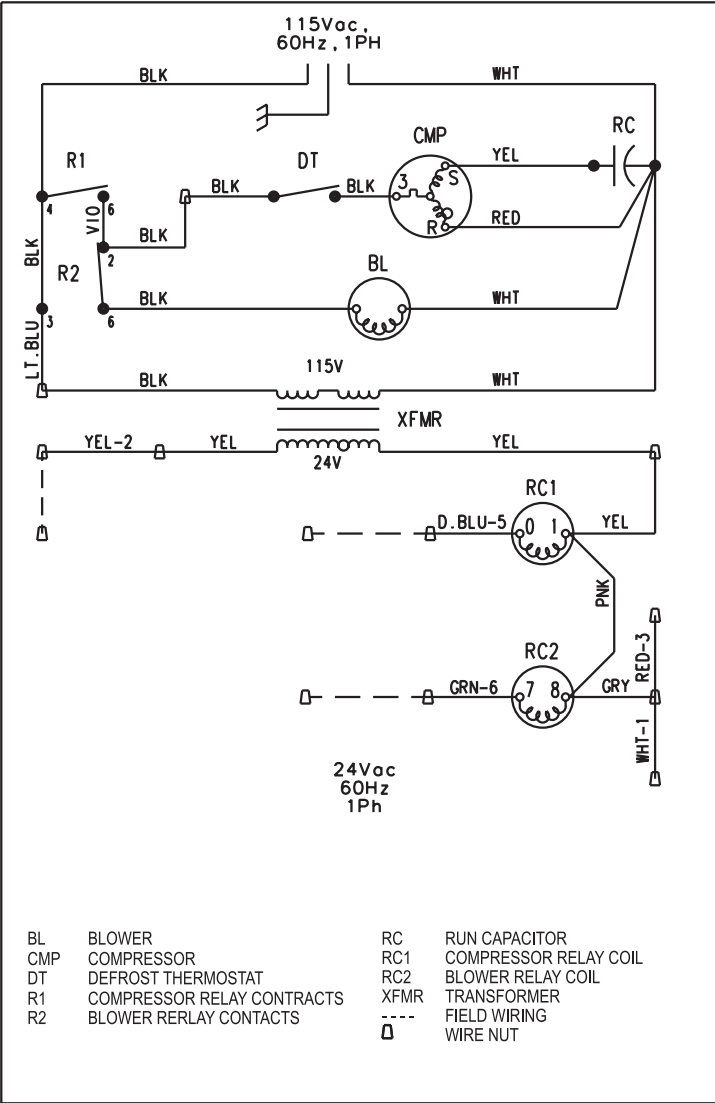

Pictorial Electrical Diagrams of Ultra-Aire XT150H

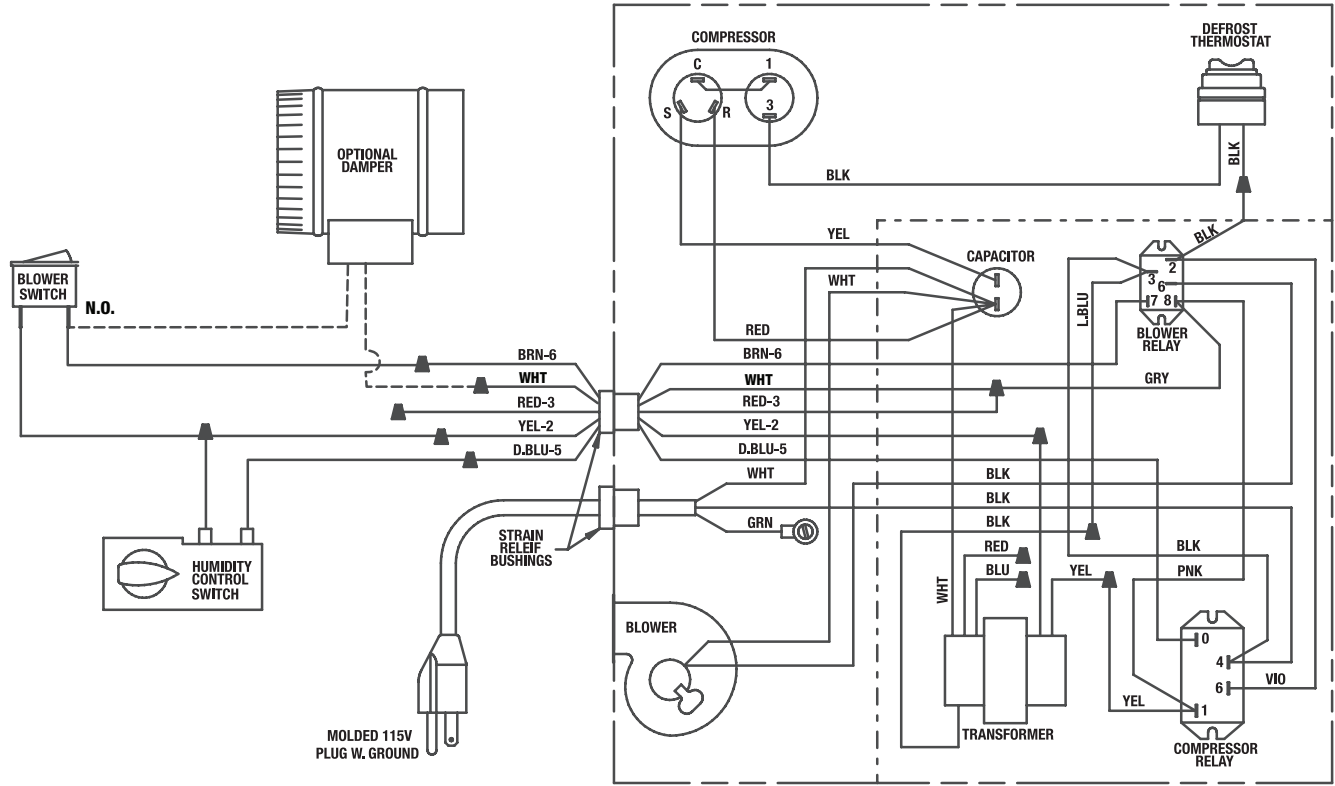

SERVICE PARTS LIST: Ultra-Aire XT150H

Item	Part No	Qty	Description
1	4026477	1	HEAT EXCHANGER
2	4026672	1	EVAPORATOR
3	4026934	2	CAPILLARY TUBES .050" X .124" X 59.00"
4	4029182	1	COMPRESSOR - TOS, 8.2 KBTU, R410A
5	4026655	1	ACCUMULATOR
6	4025087	1	FILTER/DRIER
7	4026674	1	TUBE - COND TO FILTER
8	4026472	1	TUBE - DISCHARGE LINE
9	4026673	1	CONDENSOR
10	4026657	1	IMPELLER
11	4020924	1	RELAY/BLOWER

Item	Part No	Qty	Description
12	4026687	1	45mFd CAPACITOR - COMPRESSOR
13	4022487	1	TRANSFORMER
14	4022484	1	RELAY/COMPRESSOR
15	4017021	1	15mFd CAPACITOR - IMPELLER
16	4026932	1	COLLAR 10 INCH
17	4026947	1	COLLAR OVAL 10 INCH
18	4026933	1	COLLAR W/ DAMPER 6 INCH (NOT SHOWN)
19	4026221	4	LEVELING FOOT
20	4025741	1	DEFROST THERMOSTAT (NOT SHOWN)
21	4026660	1	WIRING DIAGRAM

The Ultra-Aire XT150H

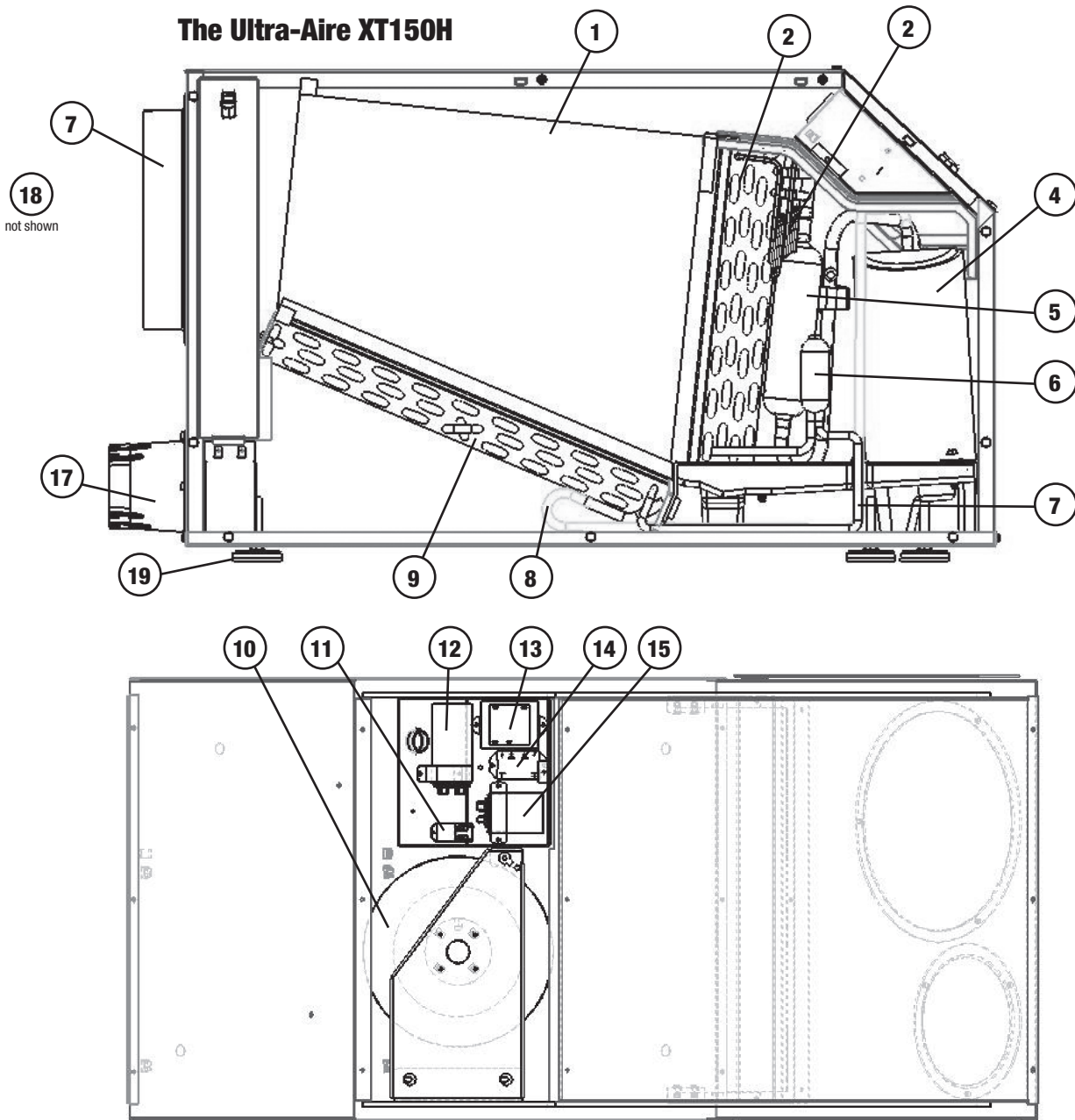

OPTIONAL PARTS LIST: Ultra-Aire XT150H

PART NO.	QTY.	DESCRIPTION
4024375	1	Check Damper, 10" Diameter
4028614	1	Condensate Pump Kit, External
4023672	1	Duct Damper, 6" Diameter, Electrically Actuated
4025560	1	Switch, Black, SPDT, On/Off
4022486	1	Timer, 7-Day, 24 Vac, Programmable
4024369	1	Merv 11 Standard Filter 20" x 16 "x 2"
4025287	1	Filter Box
4028539	1	DEH 3000 Digital Controller
4028407	1	DEH 3000R Digital Controller

DOOR AND COLLAR ASSEMBLY

Door Install

Insert tab on the bottom of the door, in between the foam installation and the metal side.

Push down on the plastic door latch and swing door shut. Once the door is shut release the door latch.

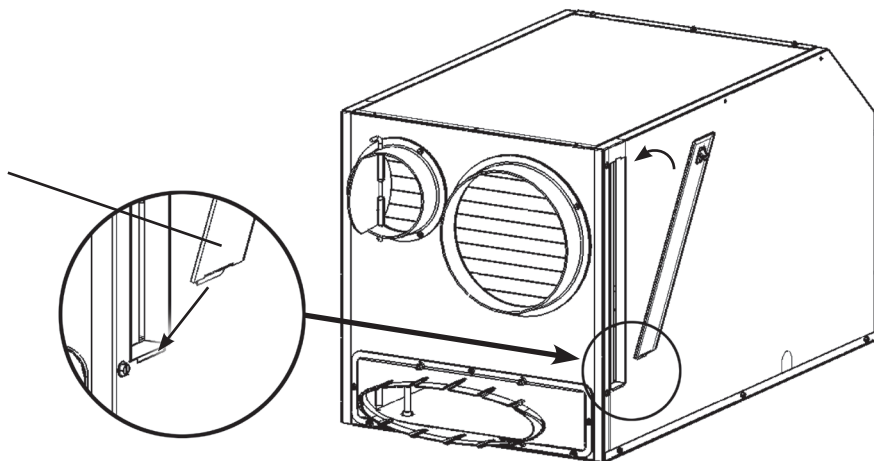

Collar Install

Remove the 2 round ducts, 3 seals and small bag of mounting hardware from inside the rectangle opening.

Adhere seals onto the back of each duct and mount the ducts to the front of the dehumidifier using screws provided.

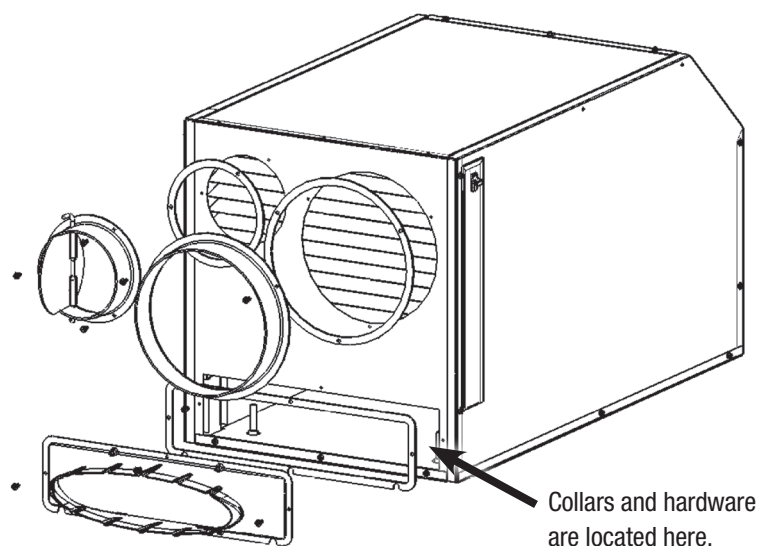



Ultra-Aire™ Limited Warranty XT150H

Limited Warranty. Therma-Stor, LLC (“Therma-Stor”) warrants as follows: (i) the Ultra-Aire XT150H dehumidifier (“Product”) will be free of material defects in workmanship or materials for a period of one (1) year (“One-Year Warranty”) following the date of initial purchase of such Product by an original customer purchasing from Therma-Stor or an authorized reseller (“Customer”); and (ii) the Product’s condenser, evaporator, and compressor will be free of material defects in workmanship or materials for a period of five (5) years following the date of initial purchase of such Product by a Customer.

Limitation of Remedies. CUSTOMER’S SOLE AND EXCLUSIVE REMEDY UNDER THE ABOVE LIMITED WARRANTY AND THERMA-STOR’S ENTIRE LIABILITY THEREUNDER, SHALL BE, AT THE SOLE OPTION OF THERMA-STOR, REPLACEMENT OR REPAIR OF SUCH PRODUCT OR ITS COMPONENTS (“COMPONENTS”) BY THERMA-STOR OR THERMA-STOR’S AGENTS ONLY. REFRIGERANT, PIPING, SUPPLIES, TRANSPORTATION COSTS, LABOR COSTS INCURRED IN REPAIR OR REPLACEMENT OF SUCH COMPONENTS ARE NOT INCLUDED. THIS DISCLAIMER AND EXCLUSION SHALL APPLY EVEN IF THE EXPRESS WARRANTY AND LIMITED REMEDY SET FORTH HEREIN FAILS OF ITS ESSENTIAL PURPOSE. CUSTOMER ACKNOWLEDGES THAT NO REPRESENTATIVE OF THERMA-STOR OR OF ITS AFFILIATES OR RESELLERS IS AUTHORIZED TO MAKE ANY REPRESENTATION OR WARRANTY ON BEHALF OF THERMA-STOR OR ANY OF ITS AFFILIATES OR RESELLERS THAT IS NOT IN THIS AGREEMENT. Notwithstanding the above, during the term of the One-Year Warranty only, Therma-Stor will provide, free of charge to Customer, all Components and labor (except costs related to removal and installation of Product) required to fulfill its obligations under such One-Year Warranty.

Disclaimer of Warranties. EXCEPT FOR ABOVE LIMITED WARRANTY, WHICH IS THE SOLE AND EXCLUSIVE WARRANTY PROVIDED WITH RESPECT TO THE PRODUCT AND ITS COMPONENTS, THERMA-STOR HEREBY DISCLAIMS ALL EXPRESS AND IMPLIED WARRANTIES, INCLUDING, WITHOUT LIMITATION, THE IMPLIED WARRANTIES OF MERCHANTABILITY AND FITNESS FOR A PARTICULAR PURPOSE.

Warranty Limitations. The foregoing limited warranty extends only to a Customer and shall be null and void upon attempted assignment or transfer. A “defect” under the terms of the limited warranty shall not include problems resulting from Customer’s or Customer’s employees’, agents’, invitees’ or a third party’s misuse, improper installation, improper design of any system in which the Product is included, abuse, lack of normal care, failure to follow written instructions, tampering, improper repair, or freezing, corrosion, acts of nature or other causes not arising out of defects in Therma-Stor’s workmanship or material. If a Product or Component is replaced while under warranty, the applicable limited warranty period shall not be extended beyond the original warranty time period. The limited warranty does not cover any costs related to changes to a Product or Component that may be required by any codes, laws, or regulations that may become effective after initial purchase of the Product by Customer.

Customer Responsibilities. As a further condition to obtaining warranty coverage hereunder, the Customer must send a valid warranty claim to Therma-Stor such that Therma-Stor receives such claim prior to the end of the applicable warranty period. Therma-Stor shall have no obligation hereunder with respect to any claim received by Therma-Stor after the expiration of the applicable warranty period. As a further condition to obtaining warranty coverage hereunder, the Customer must present forms of invoices evidencing proof of purchase of a Product. If such invoices do not clearly indicate the date of initial purchase by a Customer, the applicable Product’s date of manufacture will be used instead of the date of initial purchase for the purpose of calculating the commencement of the applicable warranty period. Warranty service must be performed by Therma-Stor or a servicer authorized by Therma-Stor. In order to obtain warranty service, the Customer should call Therma-Stor at 1-800-533-7533 and ask for the Therma-Stor Products Service Department, which will then arrange for applicable warranty service. Warranty service will be performed during customary, daytime working hours. If the Product must be shipped for service, Customer shall be solely responsible for properly packaging the Product, for all freight charges, and for all risk of loss associated with shipment.

Limitation of Liability. IN NO EVENT SHALL THERMA-STOR, IN CONNECTION WITH THE DESIGN, SALE, INSTALLATION, USE, REPAIR, REPLACEMENT OR PERFORMANCE OF ANY PRODUCT, COMPONENT, PART THEREOF OR WRITTEN MATERIAL PROVIDED THEREWITH, BE LIABLE, TO THE EXTENT ALLOWED UNDER APPLICABLE LAW, UNDER ANY LEGAL THEORY FOR ANY SPECIAL, DIRECT, INDIRECT, COLLATERAL OR CONSEQUENTIAL DAMAGES OF ANY KIND. NOTWITHSTANDING THE ABOVE LIMITATIONS AND WARRANTIES, THE SOLE AND EXCLUSIVE LIABILITY OF THERMA-STOR, REGARDLESS OF THE NATURE OR THEORY OF THE CLAIM, SHALL UNDER NO CIRCUMSTANCES EXCEED THE PURCHASE PRICE OF THE PRODUCT, COMPONENT OR PART UPON WHICH THE CLAIM IS PREMISED.

Applicable Law and Venue. ANY ARBITRATION, ENFORCEMENT OF AN ARBITRATION OR LITIGATION RELATED TO THE PRODUCT WILL BE BROUGHT EXCLUSIVELY IN DANE COUNTY, WISCONSIN, AND CUSTOMER CONSENTS TO THE JURISDICTION OF THE FEDERAL AND STATE COURTS LOCATED THEREIN, SUBMITS TO THE JURISDICTION THEREOF AND WAIVES THE RIGHT TO CHANGE VENUE. CUSTOMER FURTHER CONSENTS TO THE EXERCISE OF PERSONAL JURISDICTION BY ANY SUCH COURT WITH RESPECT TO ANY SUCH PROCEEDING.

Miscellaneous. If any term or condition of this Limited Warranty is found by a court of competent jurisdiction to be invalid, illegal or otherwise unenforceable, the same shall not affect the other terms or conditions hereof or thereof or the whole of this Limited Warranty. Any delay or failure by Therma-Stor to exercise any right or remedy will not constitute a waiver of Therma-Stor to thereafter enforce such rights.



Therma-Stor[®] LLC

PO Box 8680 • Madison, WI 53708

Phone: 608-222-5301 • Fax: 608-222-1447

Web: www.thermastor.com • Email: sales@thermastor.com

*Information in this document is subject to change without notice. No part of this document may be reproduced or transmitted in any form or by any means, electronic or mechanical, for any purpose, without the express written permission of Therma-Stor LLC.
© 2007 Therma-Stor LLC. All rights reserved.*